

GROVE GMK 4080

80 ton

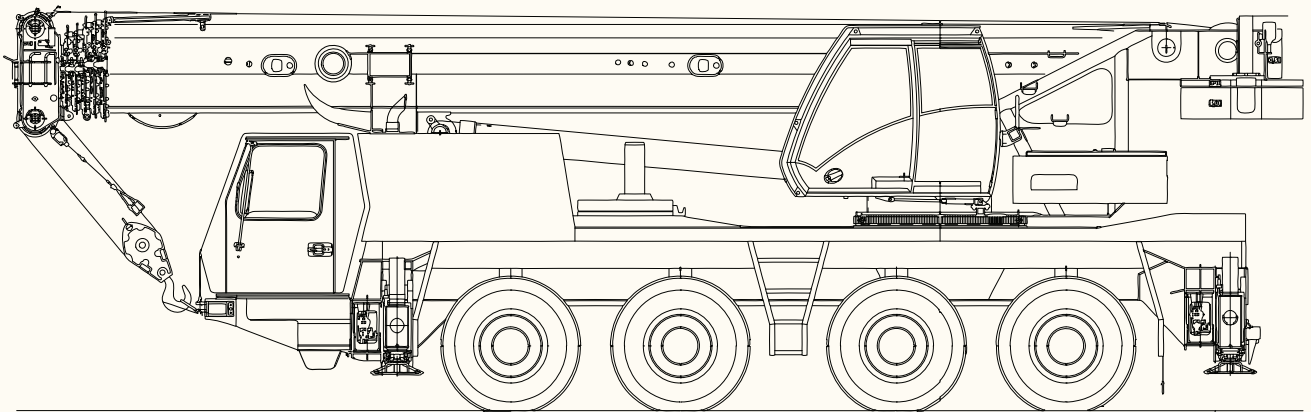

Vlucht in meters	Hoofdgiek in meters							
	11,00	19,25	27,21	31,00	39,25	43,30	47,21	51,00
3,0	8,0	53,0						
4,0	53,5	47,0	6,5					
5,0	46,0	41,5	35,0	27,5				
6,0	40,0	38,0	33,5	26,5	20,0			
7,0	34,5	34,0	31,0	25,5	19,7			
8,0	28,5	30,0	28,0	24,5	19,3	11,5		
9,0		25,5	24,0	23,0	18,2	11,5	8,9	
10,0		22,0	21,0	20,5	17,1	11,5	8,9	7,2
11,0		19,2	18,8	18,4	16,0	11,5	8,9	7,2
12,0		16,7	17,2	16,4	15,0	11,5	8,9	7,2
13,0		14,7	15,2	14,7	13,9	11,5	8,9	7,2
14,0		13,7	13,5	13,1	12,6	10,8	8,9	7,2
15,0		11,9	12,1	11,7	11,4	10,3	8,9	7,2
16,0		11,0	11,0	10,5	10,5	9,7	8,6	7,2
18,0			9,1	8,8	9,1	8,4	8,0	7,2
20,0			7,6	8,0	7,6	7,0	0,3	6,7
22,0			6,5	6,8	6,7	6,1	6,1	6,3
24,0			5,5	5,9	4,9	5,6	5,5	5,4
26,0				5,1	4,3	5,0	4,9	4,6
28,0				3,7	3,9	4,3	4,2	4,0
30,0					3,6	3,8	3,7	3,4
32,0					3,2	3,4	3,2	2,9
34,0					1,6	3,0	2,8	2,5
36,0						2,6	2,4	2,1
38,0						2,3	2,1	1,8
40,0						1,1	1,8	1,5
42,0							1,5	1,3
44,0								1,0
46,0								0,8
48,0								
50,0								
52,0								

*Betreft een samengestelde tabel waarin afwijkingen en andere configuraties mogelijk zijn.
 Houd tevens rekening met gewicht van hijsblok, hijsmiddelen, etc.

GROVE GMK 4080

80 ton

